

**Only For
\$ 1,397.80**
(Exclude GST)

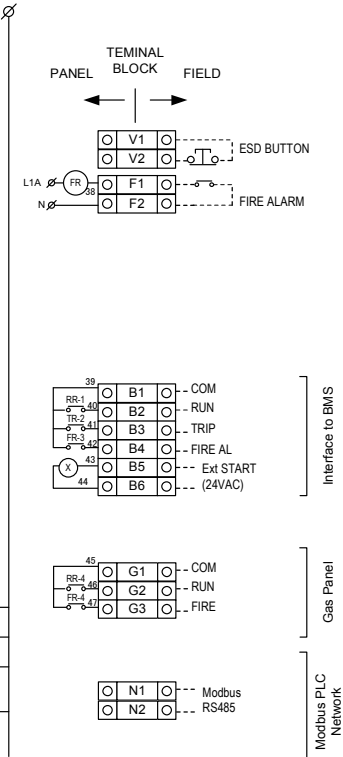
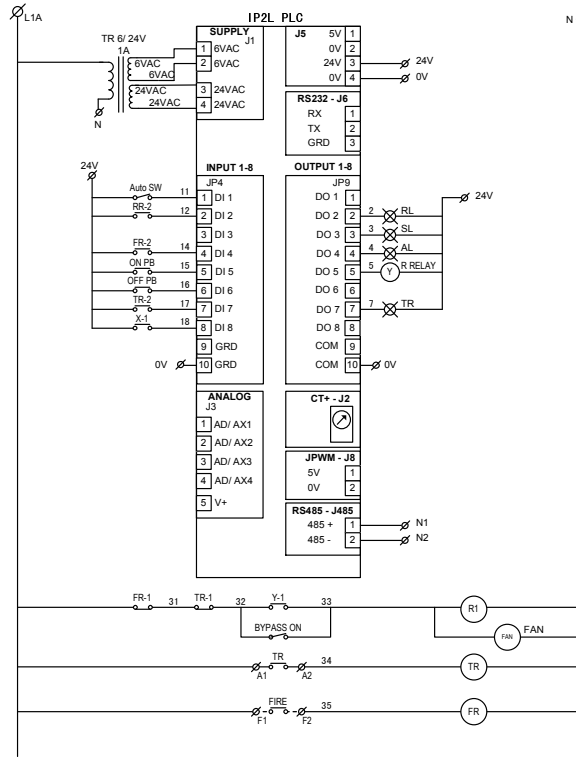
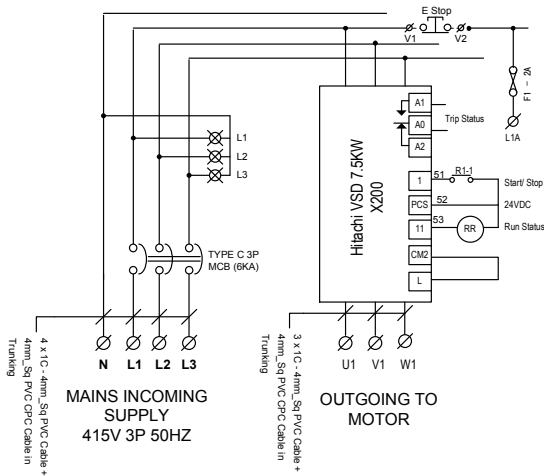
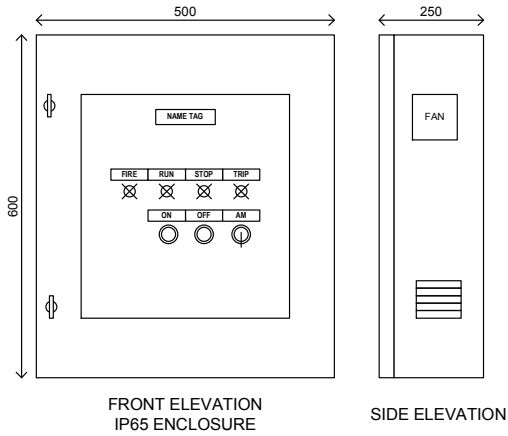

REV.	DESCRIPTION	CHECK BY	DATE

FEATURES :-

- ❖ AM MODE SELECTION
- ❖ EXT START/STOP CONTROL (24VAC)
- ❖ INTERLOCK WITH ESD/ FIRE ALARM
- ❖ PROVISION FOR VOLT-FREE CONTACTS FOR INTERFACE WITH BAS/ GAS PANEL
- ❖ MODBUS RTU (OPTIONAL)

DRAWING TITLE

LOCAL CONTROL PANEL FOR VSD <7.5KW.
EXTERNAL START/ STOP CONTROL. INTERLOCK
WITH ESD/ FIRE ALARM/ GAS PANEL. BAS
INTERFACING AND MODBUS RTU

SCALE: NOT TO SCALE DRAWN BY: WML

DATE: 13TH AUG 2010 CHECKED BY:

DRAWING NUMBER

VP3-VSD7.5