

**Only For  
\$ 705.60**  
(Exclude GST)

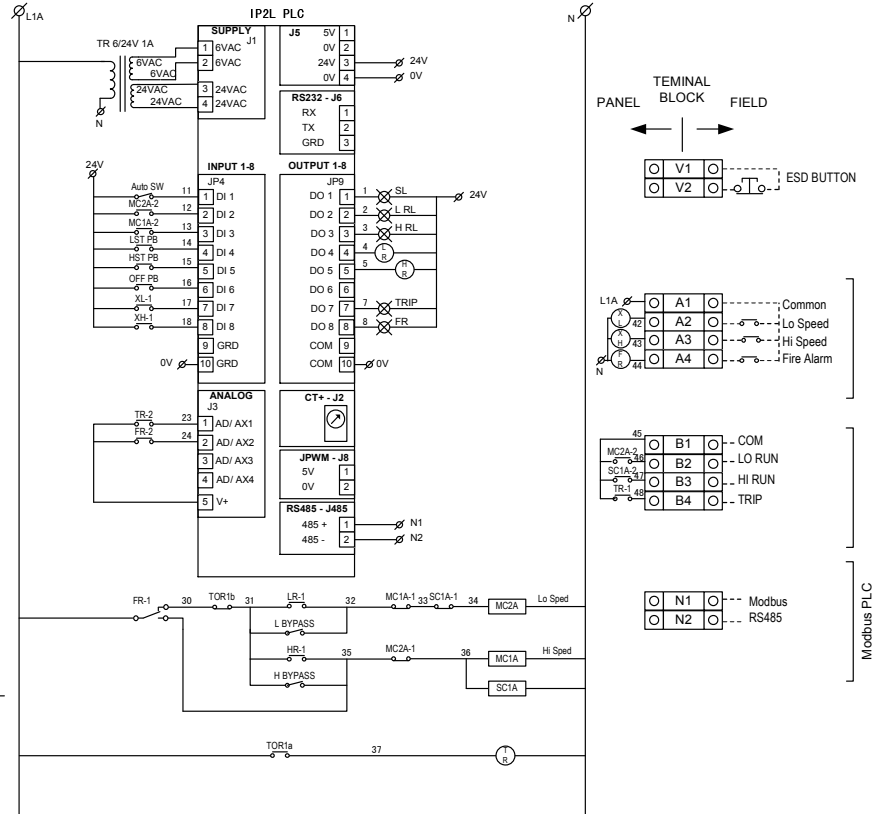
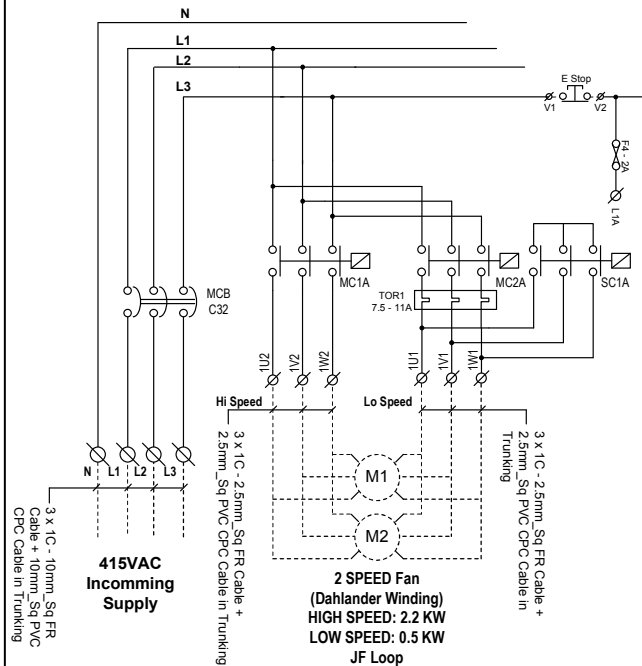
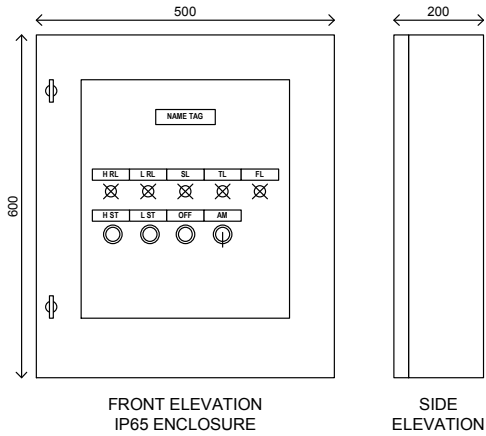

REV.	DESCRIPTION	CHECK BY	DATE

- FEATURES :-
- ❖ AM MODE SELECTION
  - ❖ EXT LO/HI START/STOP CONTROL
  - ❖ INTERLOCK WITH ESD AND FIRE ALARM (HI RUN)
  - ❖ PROVISION FOR VOLT-FREE CONTACTS FOR INTERFACE WITH BAS
  - ❖ MODBUS RTU (OPTIONAL)

DRAWING TITLE  
**LOCAL CONTROL PANEL FOR JETFAN  
 DAHLANDER 2 SPEED MOTOR <4KW, EXTERNAL  
 START/ STOP CONTROL. INTERLOCK WITH  
 ESD/ FIRE ALARM, BAS INTERFACING AND  
 MODBUS RTU**

SCALE: NTS      DRAWN BY:

DATE: 13<sup>TH</sup> AUG 2010      CHECKED BY:

DRAWING NUMBER  
 VP3-DL