

**Only For  
\$ 697.80**  
(Exclude GST)

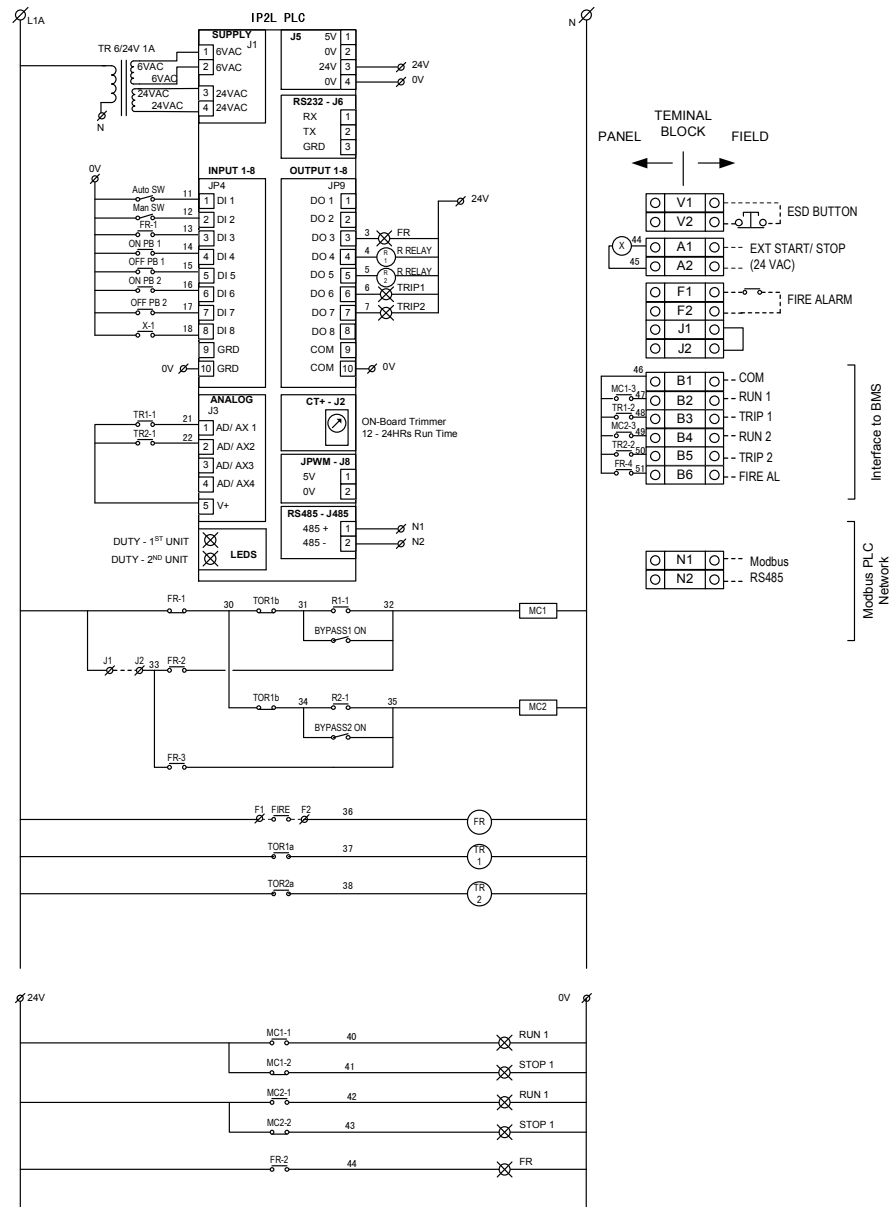
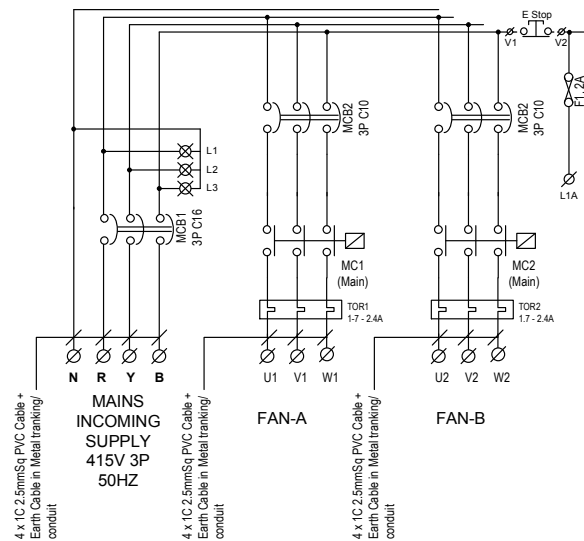
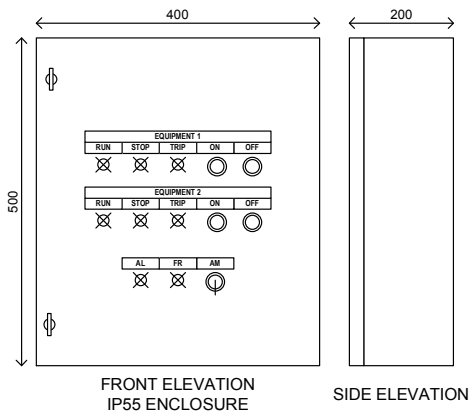

REV.	DESCRIPTION	CHECK BY	DATE

**FEATURES :-**

- ❖ 24 HOURS CHANGE-OVER PANEL
- ❖ AOM MODE SELECTION
- ❖ AUTOMATIC START OF STANDBY IN EVENT OF DUTY TRIP OR EXTERNAL ALARM
- ❖ INTERLOCK WITH ESD/ FIRE ALARM
- ❖ PROVISION FOR VOLT-FREE CONTACTS FOR INTERFACE WITH BAS
- ❖ MODBUS RTU (OPTIONAL)

**DRAWING TITLE**

LOCAL CONTROL PANEL FOR 24 HOURS DUTY-STANDBY PANEL FOR 2 X DOL STARTER <4KW. EXTERNAL START/ STOP CONTROL. INTERLOCK WITH ESD/ FIRE ALARM, BAS INTERFACING AND MODBUS RTU

SCALE: NOT TO SCALE      DRAWN BY:

DATE: 13<sup>TH</sup> AUG 2010      CHECKED BY:

**DRAWING NUMBER**

VP3-2DOL-24