

Comparing cost — 2-Wire vs. Traditional

Traditional system — Hard-wiring of I/O signals from field Local Control Panel to Status Indicating Panel. As illustration, MV Fan system for Condominium with 26 MV Fans. Each MV Fan requires eight (8) I/O signals to monitor from Main Control Panel, thus requires multi-core FR 8 x 1C 1mm2 control cables to Main Panel. The total I/O signals is 208 points in the Status Indicating Panel, thus cable support is substantial, combination of Trunking and Cable Tray.

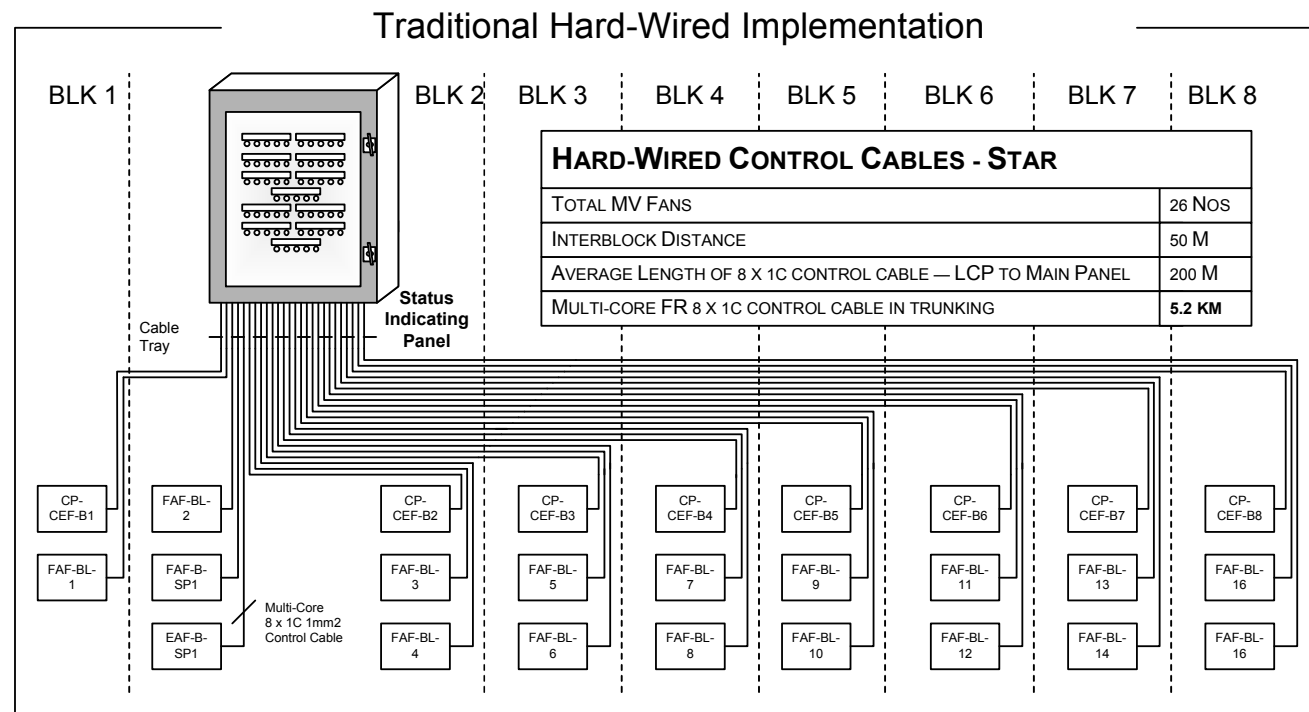

IPanel's 2-Wire MV Fan system — 1P Shielded Twisted Pair (STP) cable, looping from field Local Control Panels to Status Indicating Panel. **Cable Infrastructure — Cost savings in terms of materials, installation and commissioning cost is estimated 30%.**

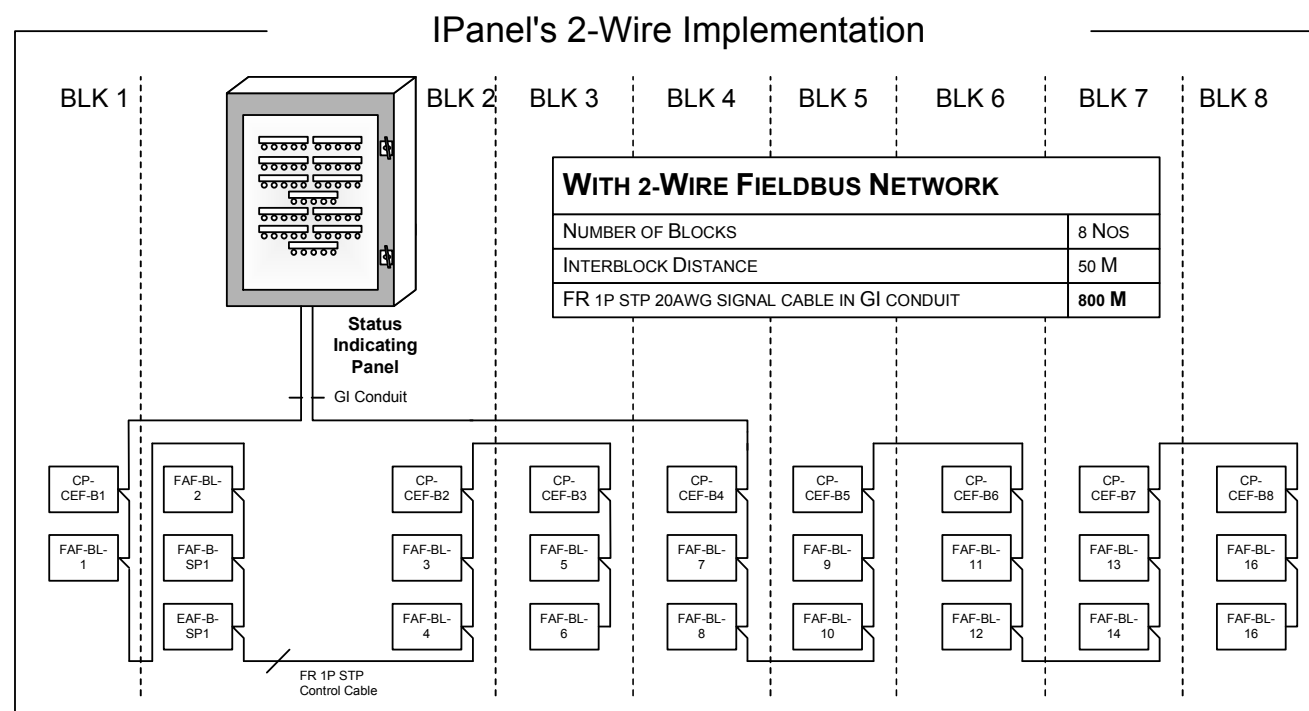

iPanel

IP2 Remote Controllers

MV Fan Fieldbus System



IPanel's 2-Wire Fieldbus Technology for MV Fan System

- Time & Cost Savings
- Simple to Use

Wire Replacement System

IPanel's IP2 Remote I/O for MV Fans

Wire Replacement System

Traditional design of MV Fan control system is costly. Each and every push button, Lamp, Selector Switch are wired all the way from field Local Control Panels to the Main Status Indicating Panel in the Control Room — Resulting in high installation cost, high maintenance costs and also future expansion problematic.

IPanel's 2-wire Fieldbus MV Fan system is simple and cost effective, bunches of control cables from Field Local Control Panels to Master Status Indicating, are replaced with a single 2-wire signal cable. Installation and commissioning work is significantly reduced, as well as, savings in time and material.

At Local Control Panel

IP2 Remote I/O unit, DIN-rail mounted, is housed inside the Local Control Panel of the MV Fan.

Control signals, like Buttons, Lamps, Selector Switches, CO2 sensor and Fire alarm points are wired within the Local Control Panel to the IP2 Remote I/O unit.

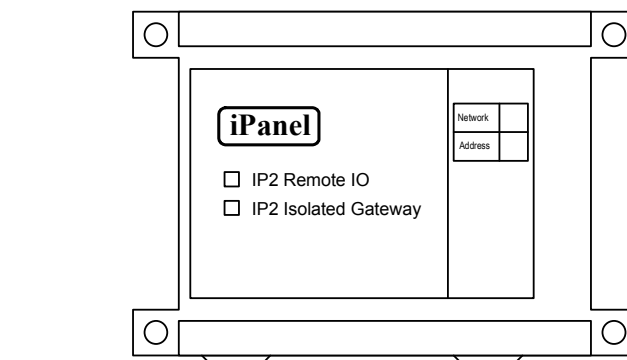

Single Pair of Cable

A single pair of network cable (Shielded Twisted Pair 18 - 20 awg) linking the Main Control Panel, looping to all the field Local Control Panels.

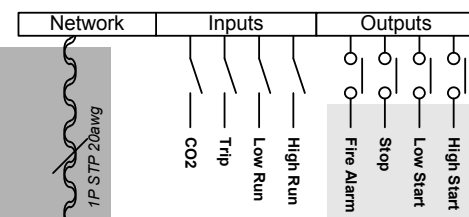

At Status Indicating Panel

The "paired" IP2 Remote I/O unit, housed inside the Main Status Indicating Panel, converts the Input (Output) signals from the field Local Control Panel to Output (Input) signals respectively.

For example, Input signals from field Local Control Panel (eg. High Run, Low Run, Trip, CO2 Alarm) are for Lamps. Conversely, Input signals (eg. High Start, Low Start, Stop, Fire Alarm) are relayed as Output contacts in the field Local Control Panel.

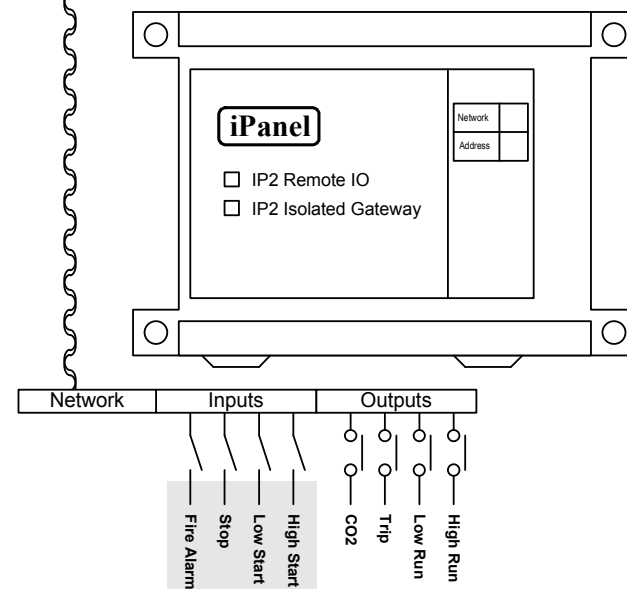

System Overview

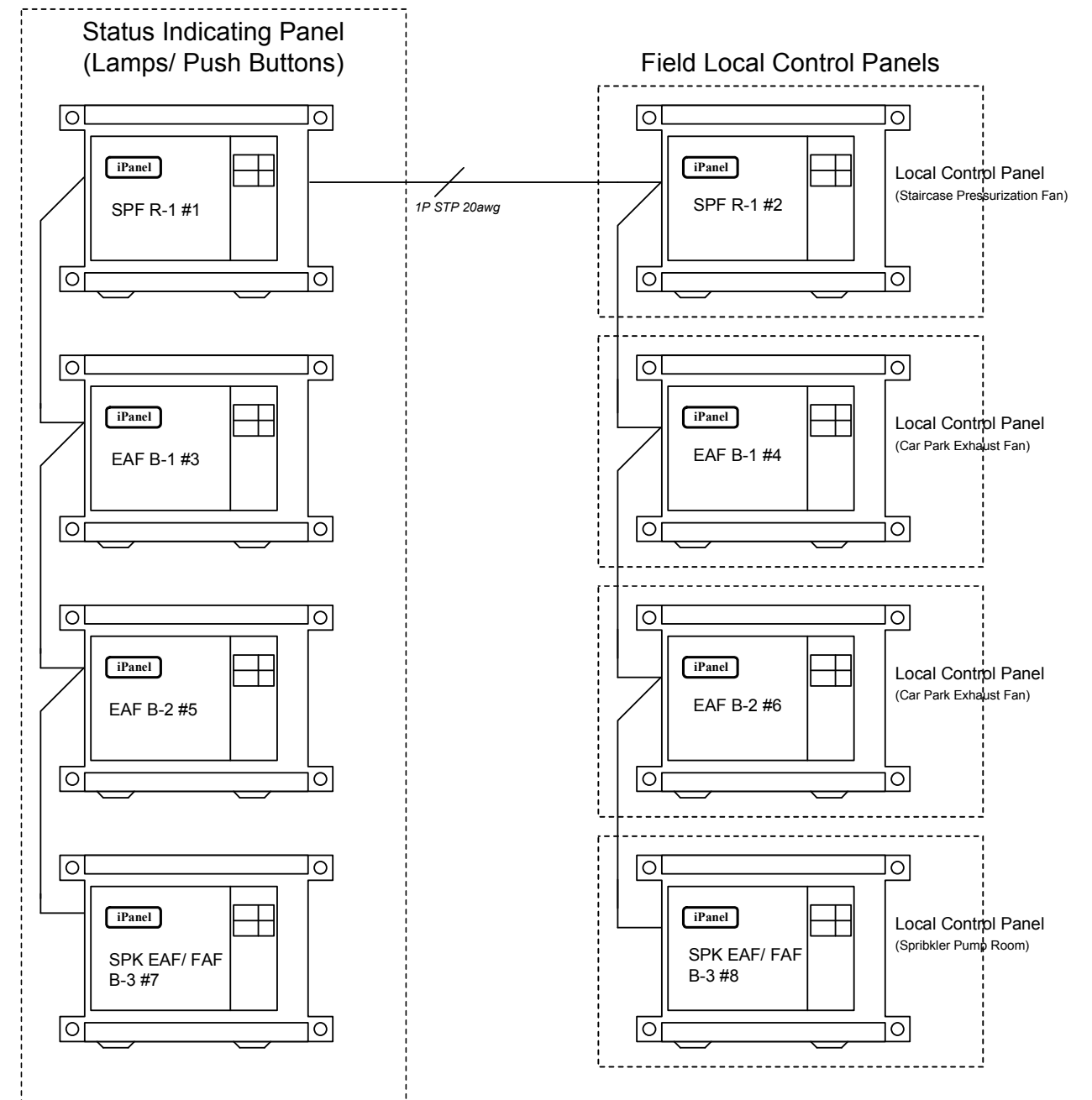

Easy To Use

- No programming
- No complex setup
- No PC for coding

IP2 Remote I/O is easy to use. I/O signals are mapped from one controller to another with simple addressing.

Simplest, Wire Replacement System available in Market !

Addressing Method

The IP2 Remote I/O with Odd Address (#10) is automatically mapped to IP2 Remote I/O with next Even Address (#11), and so forth.

Up to a maximum of 32 units of IP2 Remote I/O Units can reside in same network and maximum network length of 1,200 meters.

IP2 Remote I/O unit (IP2-RIO3) is standard Opto-Isolated with 16 Inputs and 16 Output points.