

Application Note



MV Fans Supervisory Control Panel - The Coast @ Sentosa



Project Scope :

Design, supply, testing, commissioning and maintenance of Car Park MV Fan Supervisory Control Panel - IP3C Digital Starter Panel, IP2 Digital Control Panels and PLC-Based Supervisory Control Panel

Nos. of Starter Panels :

- CP Exhaust Fans : 8
- CP Jet Fans : 8
- Fresh Air Fans : 18
- Exhaust Air Fans : 1

Description Of 2-Wire System Architecture

The Car Park MV Fan system consists of the Supervisory Control Panel (With LED Status Indicating Lamps and Push Buttons), FP2 Master PLC, IP3C Digital Starter Panels and IP2 Digital Control Panels.

Remote Monitoring And Control

The PLC of the Supervisory Control Panel (SCP) is programmed with Timer schedule for the MV Fans. Under normal conditions the MV fans are switched On/ Off based upon the Timer schedule.

Fire Control Mode

On detection of fire, all MV fans are all command to shut down by the PLC. The shut down command is broadcasted over the 2-wire network. Similarly, the PLC shall command those MV fans associated with fire control to be switch ON immediately.

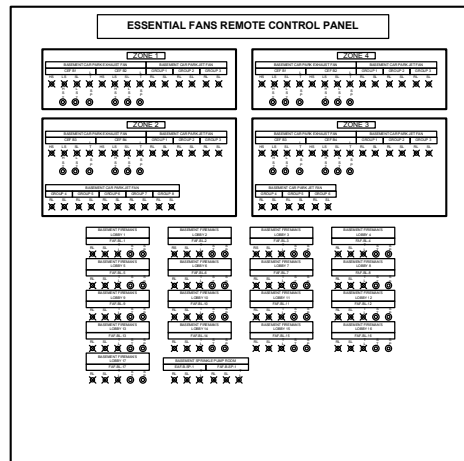

PLC-Based Supervisory Control Panel (SCP)

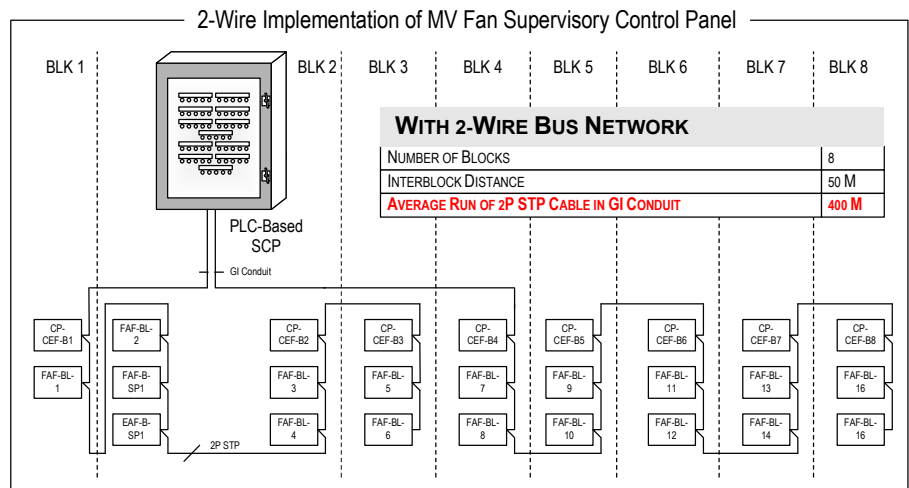

Advantageous Of 2-Wire System Architecture

The use of 2-wire Network Significantly reduces Overall cabling works by as much as Half ! For example, Reduced cable support (Cable Tray/ Conduit), Material (5,200M of multi-core cable/ 400M of 2P STP) and Manpower Costs.

Apart from the very substantial cost savings in cabling infrastructure, another advantage of this PLC-based system is the ability to sequence the Starting of MV fans. Thus, reducing starting current and not tripping Incoming supply, especially when running on Generators.

