

Application Note



Car Park Fan Supervisory Control System - One Jervois

Project Scope :

Design, supply, testing, commissioning and maintenance of Car Park MV Fan Supervisory Control System using PLC-based Starter Panels and Master Panel with Color LCD Touch Screen.



Nos. of Starter Panels :

- CP/ FAF/ EAF Fans : 53

Description Of 2-Wire System Architecture

The Car Park MV Fan system consists of the Master Panel (With 15" Color LCD Touch Screen) and IP2 PLC-based Starter Panels for MV Fans.

Remote Monitoring And Control

The Supervisory Control System is programmed with Timer schedule for the MV Fans. Under normal conditions the MV fans are switched On/ Off based upon the Timer schedule.

Fire Control Mode

On detection of fire, all MV fans are all command to RUN by the SCP. The command is broadcasted over the 2-wire network. Upon activation of the FIREMAN SWITCH, the MV fans can be switched ON/ OFF from the SCP.

Distributed Control

The PLC system is of distributed control architecture and failure of one part of the system will not render the entire system useless.

Fail-Safe Operation

To ensure reliable operation, the system is designed for Fail-Safe operation. In the event of Fire Alarm and should the system failed, remote Local Control Panels are to run automatically.

2-Wire Implementation of MV Fan Supervisory Control Panel

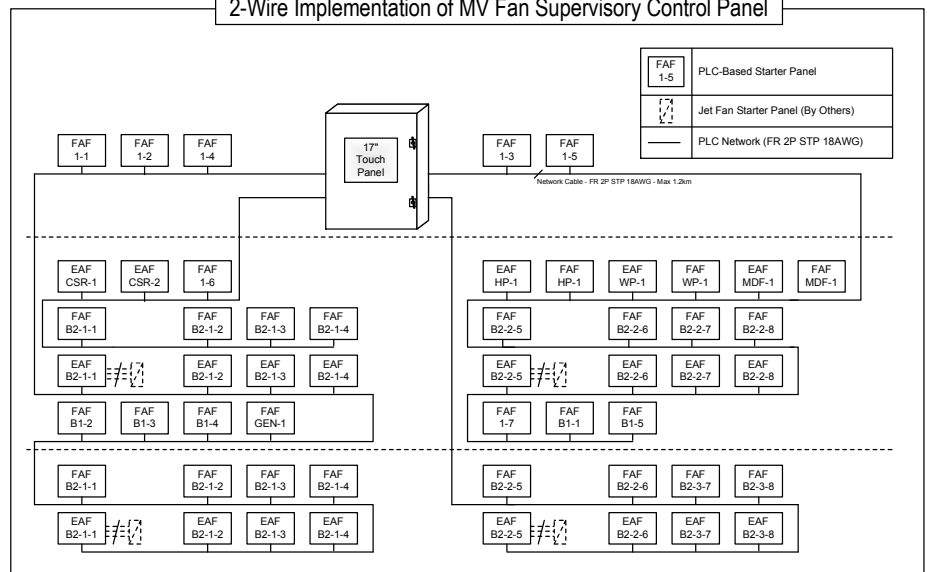

Advantageous Of 2-Wire System Architecture

The use of 2-wire PLC network significantly reduces Overall cabling works by as much as Half ! For example, Reduced cable support (Cable Tray/ Conduit), Material (200M of FR 2P STP instead of 2,600M of FR 10 Core cable) and Manpower Costs.

Apart from the very substantial cost savings in cabling infrastructure, another advantage of this PLC-based system is the ability to sequence the Starting of MV fans. Thus, reducing starting current and not tripping Incoming supply, especially when running on Generators.