

General Description

Value Panel (VP) is a range of PLC-based Control Panels commonly used in projects that we made available as standard offer and kept ex-stock, ready for installation.

Features

- ❖ IP55/ 65 Enclosure
- ❖ IP2L Programmable Logic Controller
- ❖ Mains MCB, Contactor with Overload protection
- ❖ LED Indicating Lamps for Incoming Supply, On, Off, Trip and Alarm Status
- ❖ AOM Mode Selector Switch
- ❖ Local Start/ Stop Buttons
- ❖ Incoming phase detection (Blinking Phase Lamp)
- ❖ External Start/ Stop and Interlock with Fire Alarm
- ❖ Manual Bypass ON Switch
- ❖ Volt-Free contacts for Interface with BAS
- ❖ MODBUS RTU Slave (Optional)



IP55/ 65 Enclosure

Model	Description of Control Panel	Price S\$ (Exclude GST)
VP3-DOL	DOL Starter <4kW	334. 95
VP3-DOL-CS10/30/60	DOL Starter <4kW With Current Sense Control	354. 95
VP3-SD5. 5	SD Starter <5. 5kW	504. 60
VP3-SD7. 5	SD Starter <7. 5kW	554. 60
VP3-SD11	SD Starter <11kW	602. 55
VP3-VSD7. 5-IP65	VSD (7. 5kW) IP65 Enclosure. Kitchen Exhaust Fan	1, 397. 80
VP3-DL-IP65	2 Speed JetFans <4kW Dahlander Motor. IP65 Enclosure	705. 60
VP3-DS	2 Speed Fan <4kW. Separate Windings	577. 20
VP3-2DOL-24	24 Hours Duty-Standby Panel for 2 x DOL Starters	697. 80
VP3-2FCU-24	24 Hours Duty-Standby Panel for 2 x FCU Air-Cond	697. 80

Custom Requirements

Above are models we kept as standard with Ex-stock. For Other requirements, please contact us for costing.



VALUE PANEL

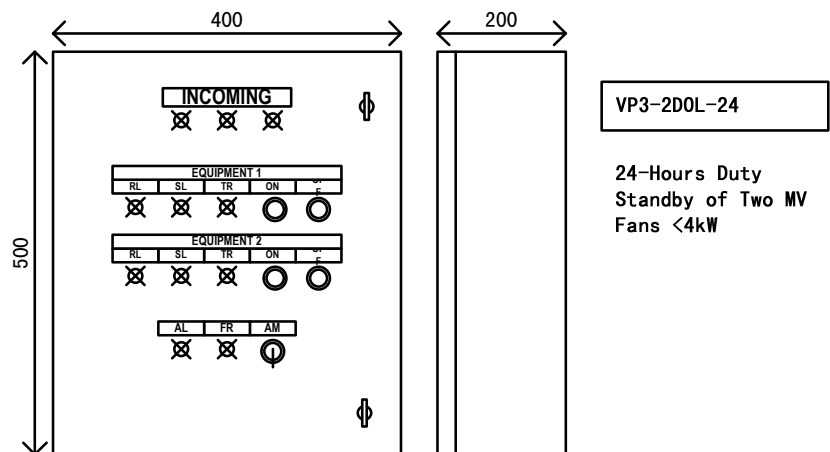
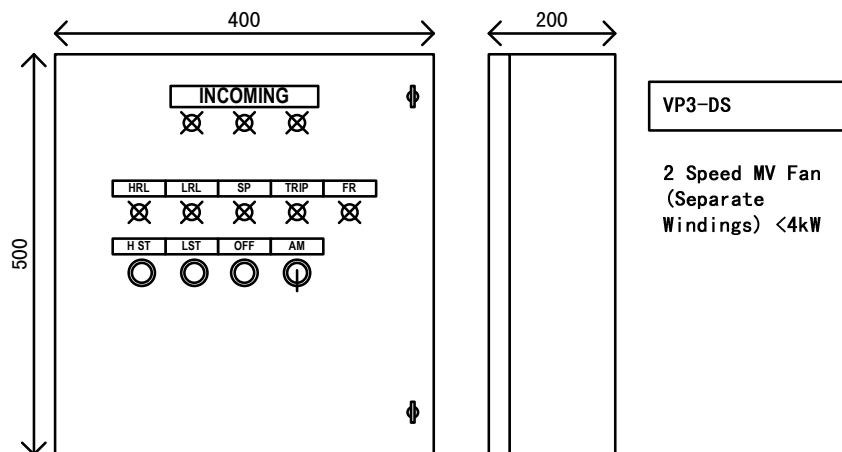
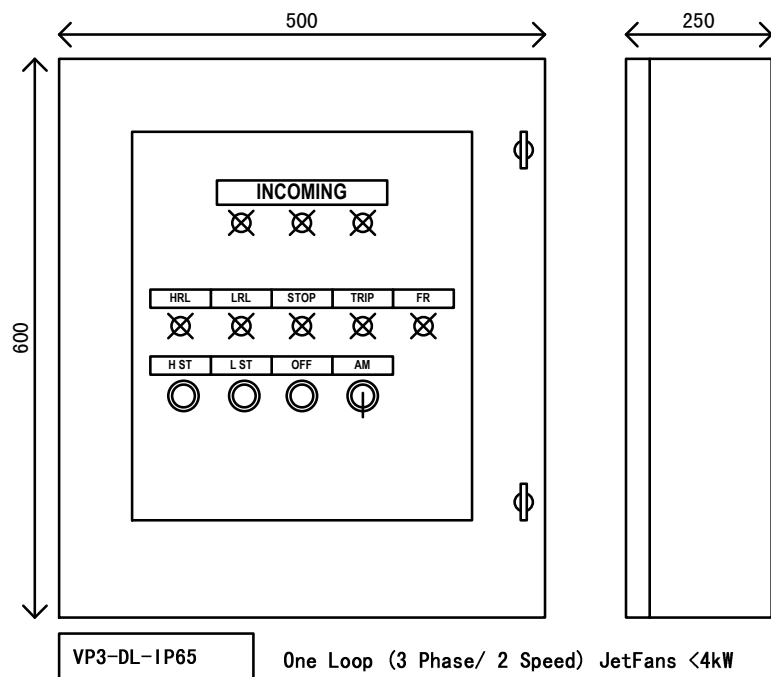
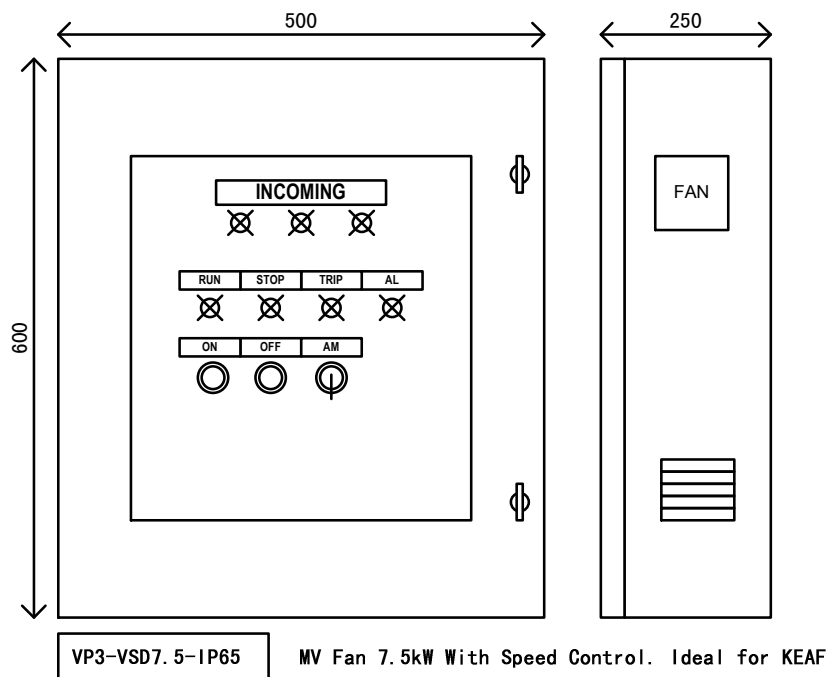
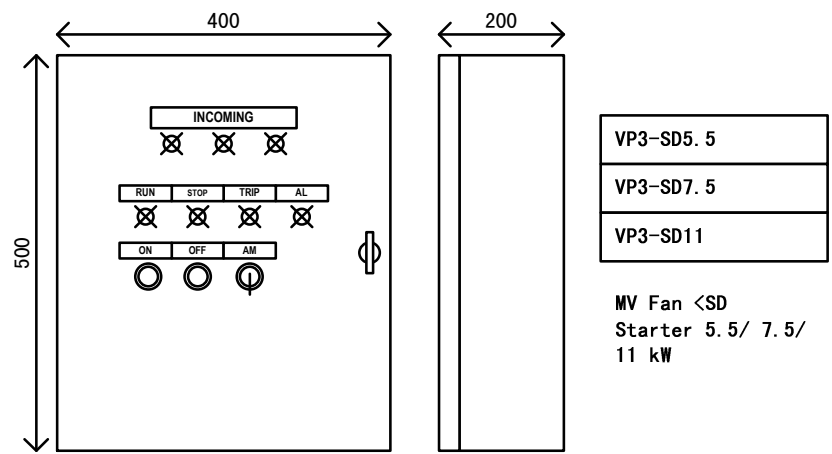
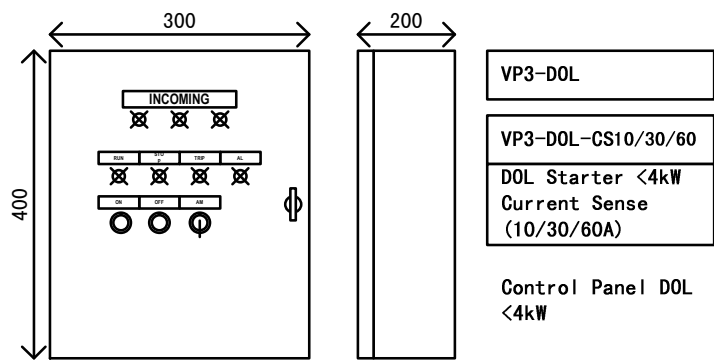

Modbus RTU

With Modbus RTU slave, VP Local Control Panels can be remotely monitored using Master Programmable Logic Controller (PLC), Touch Screen HMI or Central PC with RS485 2-Wire Network. This allows for implementation of Building Automation System.

